

# LAZER

HIGH PERFORMANCE LIGHTING

## RS8



A world first when introduced and still setting the standard, the RS-8 features three ECE approved functions in one compact unit. During daytime driving, the 20 x 0.5W LEDs illuminate to become daytime running lights (DRL). When the vehicle side lights are switched on by the driver, these LEDs run at reduced intensity, while switching on the vehicle High Beam, activates the 8 x 11W LEDs, to deliver exceptional visibility through to 350m+. Our Dual-Optic reflector system combine with advanced thermal management systems for optimising light output under all conditions.



# HYBRID OPTIC LED DRIVING LAMPS

# LAZER

HIGH PERFORMANCE LIGHTING

## RS8



- Dual optic reflector system delivers class leading distance and mid-range spread of light
- Integrated Daytime Running Light dims at night to become Position Light
- Highest output LED 'bins' selected for optimal performance
- CAE optimised heatsink and electronic thermal management
- 'Unbreakable' polycarbonate lens

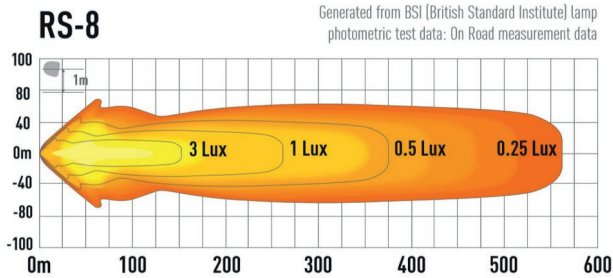

### TECHNICAL SPECIFICATIONS



E-MARK REF	12.5
VOLTAGE RANGE	9V - 32V
RAW LUMENS	7880
BEAM PATTERN	Hybrid
OPTICAL EFFICIENCY	88%
BEAM DISTANCE (0.25LX)	662m
# HIGH POWER LEDs	8 + 20
POWER CONSUMPTION	88 Watts
CURRENT DRAW <sup>†</sup>	6.2 Amps
LED LIFE	50,000 Hrs*
WEIGHT	1380g

\* LED Manufacturers Specifications <sup>†</sup>At 14.4 Volts

### MOUNTING OPTIONS:

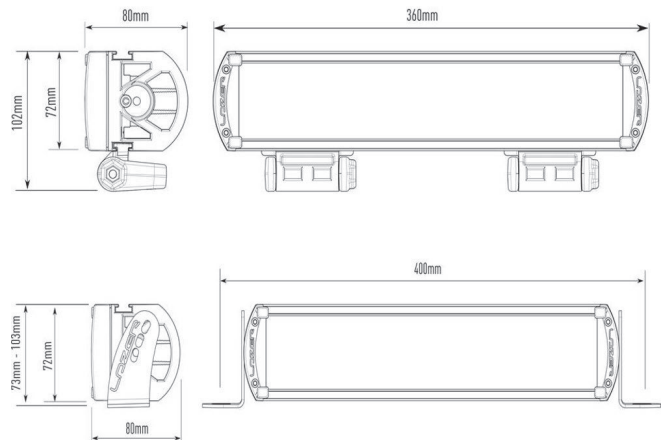

#### LAZER LAMPS LTD

Units 1+2, Harlow Mill Business Centre, Riverway, Harlow, Essex. CM20 2FD. UK

Tel: +44(0)1992 677374

Email: sales@lazerlamps.com

www.lazerlamps.com

# LAZER

HIGH PERFORMANCE LIGHTING

